

**ARCOSA**

# Arcosa Sustainability

Building a Better World

2020 SUSTAINABILITY REPORT // APRIL 2021



### **Forward-Looking Statements**

Some statements in this presentation, which are not historical facts, are “forward-looking statements” as defined by the Private Securities Litigation Reform Act of 1995. Forward-looking statements include statements about Arcosa’s estimates, expectations, beliefs, intentions or strategies for the future. Arcosa uses the words “anticipates,” “assumes,” “believes,” “estimates,” “expects,” “intends,” “forecasts,” “may,” “will,” “should,” “guidance,” “outlook,” “strategy,” and similar expressions to identify these forward-looking statements. Forward-looking statements speak only as of the date of this presentation, and Arcosa expressly disclaims any obligation or undertaking to disseminate any updates or revisions to any forward-looking statement contained herein, except as required by federal securities laws. Forward-looking statements are based on management’s current views and assumptions and involve risks and uncertainties that could cause actual results to differ materially from historical experience or our present expectations, including but not limited to assumptions, risks and uncertainties regarding Arcosa’s ability to successfully integrate Environmental, Social, and Governance initiatives (“ESG”) into our long-term strategy, Arcosa’s stakeholders and others response to Arcosa’s ESG strategy and progress, the impact of the COVID-19 pandemic on Arcosa’s customer demand for Arcosa’s products and services, Arcosa’s supply chain, Arcosa’s employees ability to work because of COVID-19 related illness, the health and safety of our employees, the effect of governmental regulations imposed in response to the COVID-19 pandemic; assumptions, risks and uncertainties regarding achievement of the expected benefits of Arcosa’s spin-off from Trinity; tax treatment of the spin-off; failure to successfully integrate acquisitions, or failure to achieve the expected benefits of the acquisitions; market conditions and customer demand for Arcosa’s business products and services; the cyclical nature of, and seasonal or weather impact on, the industries in which Arcosa competes; competition and other competitive factors; governmental and regulatory factors; changing technologies; availability of growth opportunities; market recovery; ability to improve margins; and Arcosa’s ability to execute its long-term strategy, and such forward-looking statements are not guarantees of future performance. For further discussion of such risks and uncertainties, see "Risk Factors" and the "Forward-Looking Statements" section of "Management's Discussion and Analysis of Financial Condition and Results of Operations" in Arcosa's Form 10-K for the year-ended December 31, 2020 and as may be revised and updated by Arcosa's Quarterly Reports on Form 10-Q and Current Reports on Form 8-K.

### **Non-GAAP Financial Measures**

This presentation contains financial measures that have not been prepared in accordance with U.S. generally accepted accounting principles (“GAAP”). Reconciliations of non-GAAP financial measures to the closest GAAP measure are provided in the Appendix.

# Table of Contents

<b>CEO Letter</b>	4	<b>Our Environment</b>	
<b>COVID-19 Update</b>	5	TCFD Disclosure	28
<b>Executive Summary</b>		Energy Management and GHG Emissions	37
Arcosa at a Glance	7	Water Management	38
Arcosa Overview	8	Land Management	39
Long-term Vision	9	Recycled Materials	40
Materiality Matrix	10	-----	
-----		<b>Our Products</b>	
<b>Governance &amp; Ethics</b>		Recycled Aggregates	43
Chairman's Letter	13	Arcosa Wind Towers	44
Governance Highlights	14	Arcosa Marine	45
Board of Directors	15	Arcosa Shoring Products	46
Incentive Compensation Plans	16	-----	
Ethics and Compliance	17		
ESG Statements Disclosure	18	<b>Appendix</b>	48
-----			
<b>Our People</b>			
Employee Health and Safety	21		
Inclusion and Diversity	22		
Talent Management	23		
Community Impact	24		
Designations and Recognition	26		

# A Letter From Our CEO

**2020 was a year in which businesses were faced with challenges that were more complex than traditional business problems. These complexities represent a clear sign that for a business to be successful in the future, it will have to address Environmental, Social, and Governance (“ESG”) aspects in a more deliberate manner.**

Last year, we highlighted the importance of ESG in the new culture we are building at Arcosa. We continue to view sustainability as one of the four key pillars of our long-term strategy. The key components identified in our 2019 materiality assessment are being integrated into our Strategic Planning and our Enterprise Risk Management processes. When we look at ESG both from a risk and an opportunity point of view, we can make decisions to mitigate risks and at the same time identify opportunities that are being created by the fast-changing environment.

One example of the opportunities we have identified is our entrance into recycled aggregates, a new product category for Arcosa, through two acquisitions in 2020. Recycled aggregates offer environmental benefits, by helping to preserve a scarce natural resource, as well as, reduce greenhouse gas emissions. We believe having the ability to offer our customers a complementary set of natural and recycled aggregates is a strategic advantage as environmentally friendly construction takes on greater prominence. Applying an ESG filter to our strategic planning process is helping our company find new and exciting growth opportunities.

Like no other year, 2020 highlighted the importance of focusing on our most valuable asset - our employees. Employee health and safety is a key focus area of our ESG program. In response to the COVID-19 pandemic, we reviewed our procedures, and I am very proud to say that we always kept employee health and safety at the forefront of every COVID-19 related decision we made.

We continue to make significant progress in the implementation of ARC 100, our company-wide safety program launched in 2019 in close partnership with a leading safety culture consultant. Our goal is to achieve positive measurable change in our safety culture by empowering employees to take active ownership of their health and safety. Our future success is predicated upon the health and talent of our organization, and I want to thank the entire Arcosa team for their unwavering dedication and resilience this year.

I am proud to say that our ESG efforts have become an even more important tool in keeping Arcosa focused on our values and long-term strategy. At the same time, we recognize this is a long journey and we are just getting started.

I am pleased to share with you Arcosa’s 2020 Sustainability Report, highlighting the strides we have taken to advance our ESG program. Some noteworthy steps taken this year include integration of the Financial Stability Board’s Task Force on Climate-related Financial Disclosures (TCFD) framework and broadened supporting metrics from the Sustainability Accounting Standards Board (SASB).

As our focus has shifted to 2021 and beyond, our promise remains the same: At Arcosa, our goal is to integrate sustainability into our daily practices as well as our long-term strategy. This promise is key to building a resilient company and a better world.



**Antonio Carrillo**  
President and Chief Executive Officer



# COVID-19 Update

Our businesses support critical infrastructure sectors, as defined by the Department of Homeland Security's Cybersecurity and Infrastructure Security Agency (CISA.gov); these critical sectors are deemed essential to infrastructure. Our plants have continued to operate to meet our customers' needs while also keeping employee health and safety as our most important priority.

## Employee Health

Arcosa's priority remains the health and safety of our employees.

We implemented safeguard measures at our plant and office locations to meet or exceed the standards set forth by CDC guidelines.

Arcosa's collaborative leadership team continues to monitor and align practices with current guidance, prioritizing the health and safety of our employees.

As changes to protocol shift and where utmost safety can be maintained, we have cautiously begun to open facility access to key visitors and contractors, allowing in-person support to our business locations and employees.

## Community Support

2020 presented challenges to many communities in which we operate.

Arcosa plants advocated for food drives in their communities, supporting those adversely impacted by the pandemic.

Our corporate community impact team led the way in the Dallas, TX region to innovate the way Arcosa participated in charitable events virtually.

As back-to-school became a reality for many cities, our plants provided school supplies, as well as cleaning and sanitation products to our local schools.

## Business Resilience

As an essential business, Arcosa continued operations in 2020, focusing on sustainability and resilience in the face of challenge.

Our employees demonstrated relentless dedication and effort to keep our operations safe as we delivered critical infrastructure products and services across North America.

Arcosa continued to build a "cash culture", allowing us to remain agile and invest in attractive acquisitions despite COVID-19 related economic uncertainty.

ESG remained a high priority as Arcosa's businesses integrated sustainability into strategy, aligning operations with awareness of our impact to the world around us.

# Executive Summary

Arcosa at a Glance	7
Arcosa Overview	8
Long-term Vision	9
Materiality Matrix	10

# Arcosa at a Glance

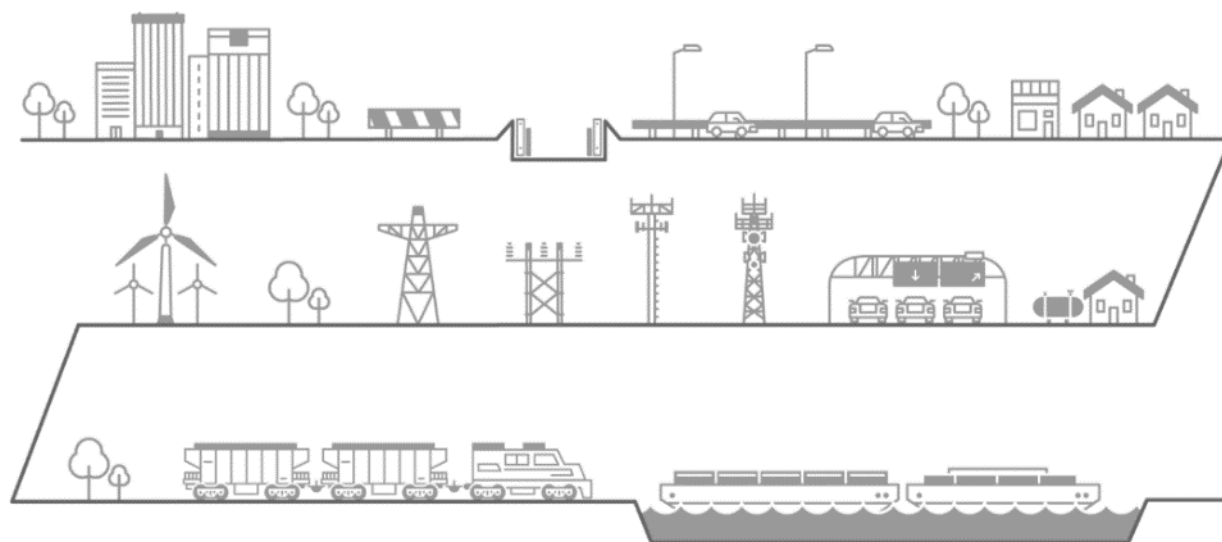

**\$1.9B Revenues**

**\$107M Net Income**

**\$284M Adjusted EBITDA**

**~6,410 Employees**

**85+ Years of Operating History**

**3 Infrastructure-related Segments**

Revenues, Adjusted EBITDA and Net Income are for the fiscal year ended 12/31/2020. See [Adjusted EBITDA reconciliation in Appendix](#).

# Business Overview

Arcosa's three segments are made up of leading businesses that serve critical infrastructure markets

## Markets

**CONSTRUCTION**



**NATURAL &  
RECYCLED  
AGGREGATES**



**SPECIALTY  
MATERIALS**



**CONSTRUCTION  
SITE SUPPORT**

**ENGINEERED  
STRUCTURES**



**UTILITY,  
TELECOM, &  
TRAFFIC  
STRUCTURES**



**WIND TOWERS**



**STORAGE  
TANKS**

**TRANSPORTATION**



**BARGES**



**COMPONENTS**



## Our Long-Term Vision



**Grow** in attractive markets where we can achieve sustainable competitive advantages



**Reduce** the complexity and cyclical nature of the overall business



**Improve** long-term returns on invested capital

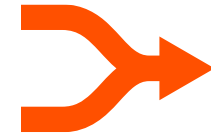

**Integrate** ESG into our long-term strategy

At Arcosa, we are unified in our commitment to build a better world

# Materiality Matrix

Arcosa’s materiality matrix is foundational to our ESG Program. The matrix is built on a materiality assessment developed with outside consultants. We partnered with key internal and external stakeholders to understand the sustainability issues that most affect our businesses. The Sustainability Accounting Standards Board (“SASB”) standards are the basis for our reporting approach and our materiality assessment.

Topics rated highly material are in the top right of the matrix, with Air Quality, Business Ethics and Compliance, Inclusion and Diversity, and Employee Health and Safety as our highest priorities in the near-term.

The matrix is the result of Arcosa’s first assessment, performed in late 2019. The topics identified in the assessment were reviewed and discussed routinely during 2020 in response to the cultural events that shaped the year, including COVID-19 response and social justice issues. While no changes were deemed needed at this time, we continue to monitor and reflect on stakeholder needs to ensure our matrix remains meaningful.

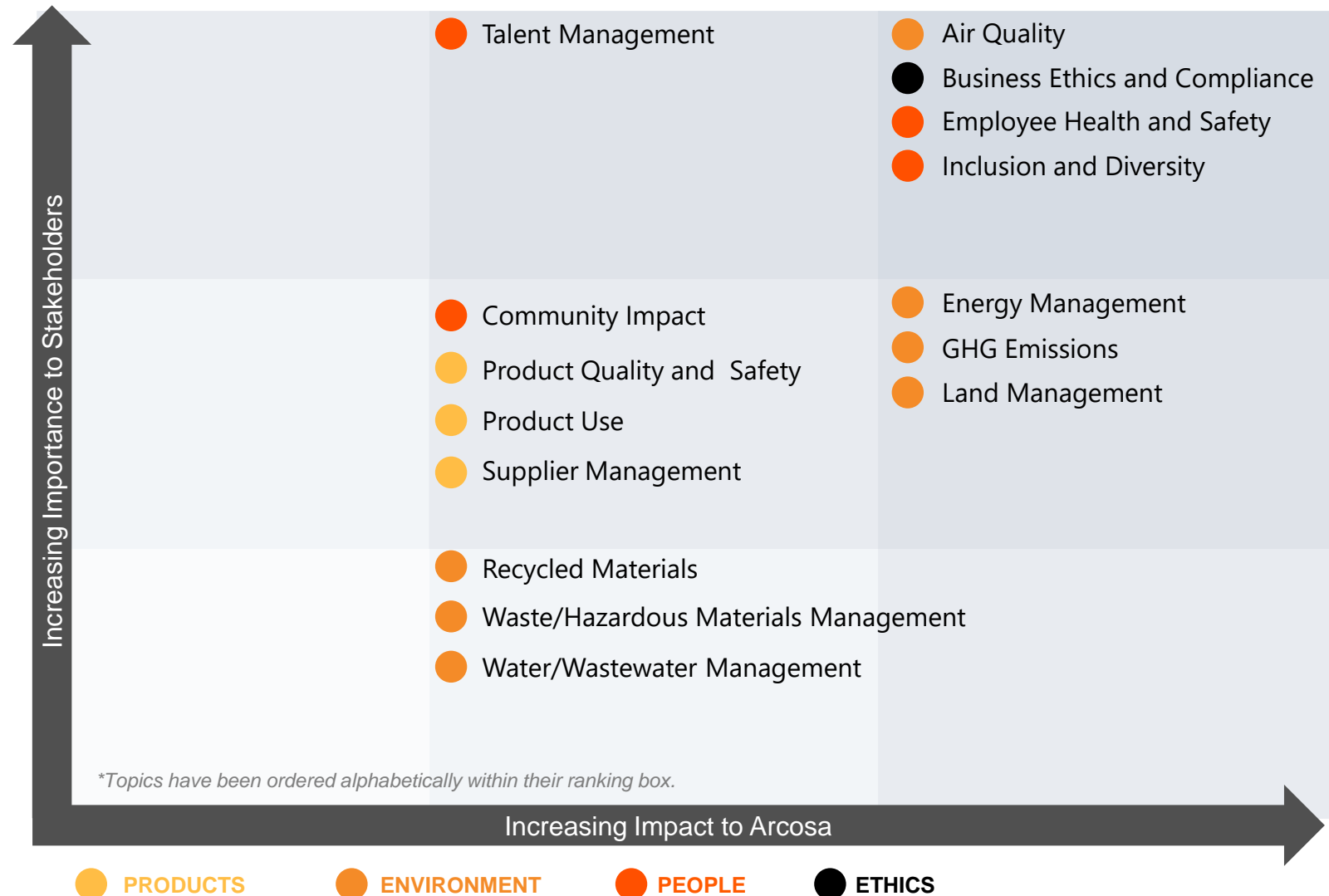

We are committed to developing reportable metrics and establishing meaningful goals in areas important to our stakeholders.



## Our People

- Community Impact
- Inclusion and Diversity
- Employee Health and Safety
- Talent Management

## Our Environment

- Air Quality
- Energy Management
- GHG Emissions
- Land Management
- Recycled Materials
- Waste Management
- Water Management

## Our Products

- Product Quality and Safety
- Product Use
- Supplier Management

## Governance & Ethics

Chairman's Letter	13
Governance Highlights	14
Board of Directors	15
Incentive Compensation Plans	16
Ethics and Compliance	17
ESG Statements Disclosure	18

## Chairman's Perspective on Sustainability

**“We understand the significance of ESG-focused strategy and the many ways in which sustainability impacts our stakeholders.”**

On behalf of Arcosa, thank you for your interest in our 2020 Sustainability Report. Our company is a provider of infrastructure-related products and solutions with leading brands serving construction, engineered structures, and transportation markets across North America. Arcosa became a public company in late 2018; however, our individual businesses have built reputations for quality, service, and operational excellence over many decades.

In a year of unprecedented change and development, we see the future of ESG continuing to gather momentum. In 2020, our views on prioritizing the health and safety of our employees, supporting our diverse communities, and improving the environmental impact we leave on the world came further into focus. This report highlights the many ways Arcosa is committed to building a better world.

Arcosa's Board of Directors embraces the continued responsibility to provide oversight of the company's risks, with continued focus on ESG efforts to ensure operational resilience.

Over the course of 2020, we made important strides in our ESG program:

- In July, we published a series of policy statements fundamental to our core sustainability values.
- In August, we published a Mid-year ESG Report to highlight many of our sustainability-focused businesses and activities, as well as to disclose the results of our materiality assessment.
- In September, we renamed the Board's Corporate Governance and Directors Nominating Committee to the Governance and Sustainability Committee, further clarifying the Board's focus on ESG.

As Arcosa embarks on 2021, we reflect on the progress made in 2020 with an eye to the future. Our vision of integrating ESG initiatives into our long-term strategy remains strong as we build on the foundational steps we've paved in 2020.

**Rhys J. Best**  
Chairman of the Board



# Governance Highlights

Our policies are aligned with stakeholder value creation

## Board Composition

**Independent Board:** 8 of 9 directors are independent

### Independent Committees

- Audit
- Human Resources
- Governance and Sustainability

**Separate CEO and Independent Board Chair**

## Board Practices

**Regular executive sessions with independent directors**

**Board oversees risk management activities including annual Enterprise Risk Management assessment**

**Annual Board and Committee self-performance evaluations**

## Accountability

**Extensive shareholder engagement program**

**Majority voting for uncontested director elections**

**Board to be declassified as of the 2022 annual meeting**

## Share Ownership / Compensation

**“Pay for performance” compensation structure**

**Robust stock ownership requirements for senior management and directors**

**Prohibition of hedging and pledging of our shares**

**Clawback policy in place**

**No perquisites plan**

*In 2020, Arcosa’s Board emphasized the importance of ESG by broadening the oversight of the Governance and Sustainability Committee to include oversight specific to Sustainability, including an updated committee charter, formal review of ESG matters in committee meetings, and an updated name.*

# Board of Directors

Diverse group of leaders with C-Suite and Independent Director experience



## Antonio Carrillo

- ✓ President & CEO, Arcosa
- ✓ Significant knowledge and understanding of Arcosa's products, services, operations, and business environment and has experience leading a significant industrial enterprise in Mexico, where Arcosa has a number of operations



## David Biegler

H I

- ✓ Former Vice Chairman, TXU Corp.
- ✓ Broad experience managing and leading a significant industrial enterprise; provides the Board with additional perspective on the Company's operations, including engineered structures businesses



## Douglas Rock

A I

- ✓ Former Chairman & CEO, Smith International
- ✓ Broad experience managing and leading a significant industrial enterprise; provides the Board with additional perspective on the Company's operations, including engineered structures businesses

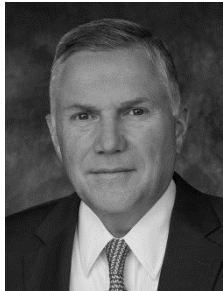

## Jeffrey "Jay" Craig

A I

- ✓ Executive Chairman, Meritor
- ✓ Significant management experience provides the Board with additional perspective on the Company's operations, including transportation products businesses

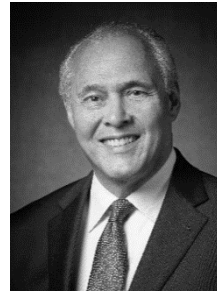

## Joe Alvarado

H G I

- ✓ Former Chairman & CEO, Commercial Metals Company
- ✓ Significant management experience provides the Board with additional perspective on the Company's operations, including construction products and steel-fabrication businesses

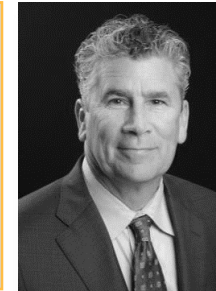

## John Lindsay

H I

- ✓ President & CEO, Helmerich & Payne
- ✓ Significant management experience provides the Board with additional perspective on the Company's operations, including engineered structures businesses



## Melanie Trent

G A I

- ✓ Former EVP, General Counsel & Chief Administrative Officer, Rowan Companies
- ✓ Strong legal & executive management experience, diverse background and knowledge of oil and gas industry; provides the Board with additional perspective on the Company's operations

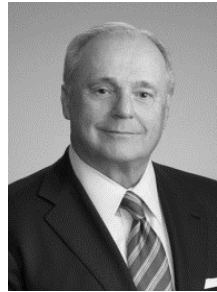

## Rhys Best

C

- ✓ Former Chairman & CEO, Lone Star Technologies
- ✓ Extensive experience managing and leading significant industrial enterprises; provides the Board with additional perspective on the Company's operations, including construction products and engineered structures businesses



## Ron Gafford

G I

- ✓ Former President & CEO, Austin Industries
- ✓ Broad experience managing and leading a significant industrial enterprise; provides the Board with additional perspective on the Company's operations, including construction products businesses

**C** Independent Chair

**I** Independent Director

**A** Audit Committee

**G** Governance & Sustainability Committee

**H** Human Resources Committee

See 2021 Proxy Statement for more detailed Board biographies

# Incentive Compensation Plans

Arcosa's incentive plans align compensation to long-term stakeholder value creation while driving accountability to the business level

	Award Type	Focus	Performance Objectives
Short Term Incentive Plan (STI)	Cash	1 year operational and financial targets	Adjusted EBITDA Strategic Initiatives (ESG, Safety, Growth) Business-specific Metrics
	Equity: Performance-Based Restricted Stock Units	Long term stakeholder value creation	Return Metrics
Long Term Incentive Plan (LTI)	Equity: Time-Based Restricted Stock Units		Earnings Metrics

2020 Target CEO Pay: 83% at Risk

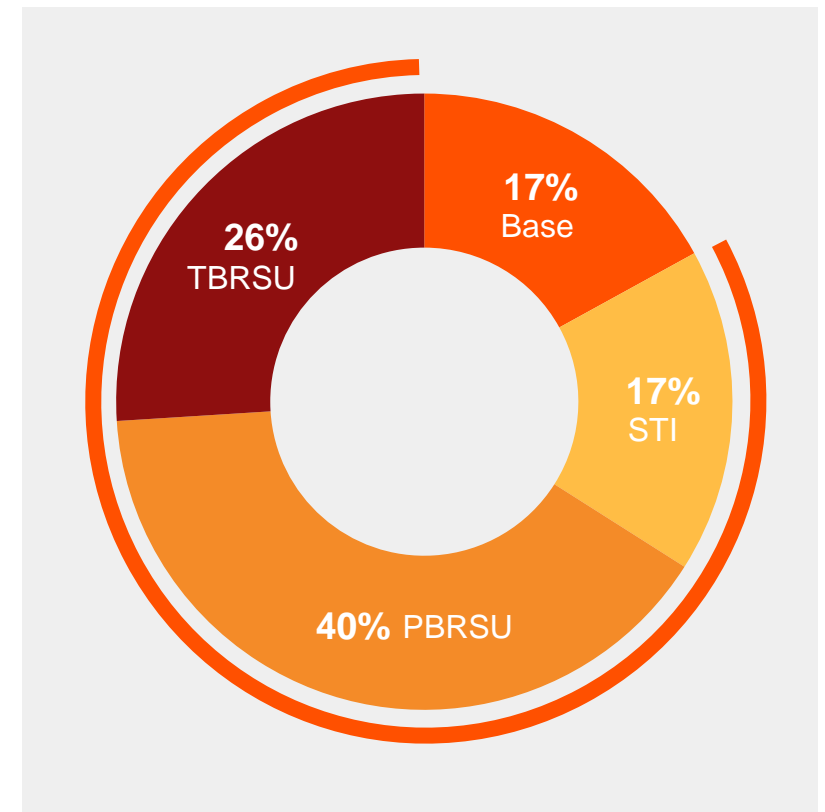



# Ethics and Compliance

Key Policies & Statements	Objective	Approach
<b>Code of Business Conduct and Ethics</b>	Ensure employees are trained periodically on expected behavior related to policies, laws, and regulations	<ul style="list-style-type: none"> <li>Annual code training and certification</li> <li>Easy access to Code and anonymous reporting channels</li> </ul>
<b>Health and Safety</b>	Maintain standards and practices that protect the health and safety of stakeholders	<ul style="list-style-type: none"> <li>Advance a Safety culture through ARC 100 program</li> <li>Tailored Occupational and Process Safety</li> <li>Examine contractor safety programs</li> </ul>
<b>Environmental Responsibility</b>	Publish, educate, and incentivize workforce to develop environmental awareness and reduce environment footprint	<ul style="list-style-type: none"> <li>ESG training for employee knowledge building and to spark day-to-day innovation</li> <li>Strategic business initiatives driven by leadership teams across Arcosa</li> </ul>
<b>Foreign Corrupt Practices Act (FCPA)</b>	Zero tolerance toward acts of corruption (prohibition of facilitation payments), and prohibition of providing benefits to public officials	<ul style="list-style-type: none"> <li>Train impacted employees annually</li> <li>Train impacted agents and third-parties representing Company interests annually</li> </ul>
<b>Diversity and Anti-Harassment</b>	Provide an inclusive and diverse workplace free from retaliation and unlawful discrimination or harassment	<ul style="list-style-type: none"> <li>Initial training occurs during employee onboarding</li> <li>Key topic in Code of Conduct training</li> <li>Targeted, periodic civil treatment training</li> <li>Training to end unconscious bias</li> </ul>
<b>Cybersecurity</b>	Ensure confidentiality, integrity, and availability of the Company's computer networks, applications, devices, and data	<ul style="list-style-type: none"> <li>Audit committee oversight; quarterly meetings</li> <li>Additional risk mitigation through information security insurance</li> <li>Externally audited under CIS standard</li> <li>Defense in depth approach; multiple layers of security</li> <li>Robust technology training for employees</li> <li>No material security breaches in ~3 years as a public company</li> </ul>

## Key items addressed in Arcosa policies and statements, including the Code:

- Adhere to all laws and regulations
- Health and safety paramount
- Treat others with dignity and respect
- No tolerance for harassment or discrimination
- Prohibition of anti-competitive practices
- Anti-corruption: Forbid giving or receiving bribes
- Maintain whistleblowing HelpLine and HelpSite; no tolerance for retaliation



# ESG Statements Disclosure

Furthering Arcosa's commitment to integrate Sustainability into our short-term priorities and long-term strategy, we have published a series of formal policy statements to our website [www.arcosa.com/sustainability](http://www.arcosa.com/sustainability). These statements bring into focus our stance on important issues identified by our stakeholders

## ENVIRONMENTAL



- Statement on Air Quality\*
- Statement on Biodiversity\*
- Statement on Climate Change\*
- Statement on Environmental Responsibility\*
- Statement on Waste Management\*
- Statement on Water Management\*

## SOCIAL



- Statement on Diversity\*
- Statement on Human Rights\*
- Statement on Occupational Health and Safety\*
- Statement on Suppliers\*

## GOVERNANCE



- California Transparency in Supply Chains Act of 2010 Corporate Disclosure
- Categorical Standards of Director Independence
- Code of Business Conduct and Ethics
- Corporate Governance Principles
- Whistleblower Policy

\* Denotes new disclosures in 2020

## Our People

Employee Health and Safety	21
Inclusion and Diversity	22
Talent Management	23
Community Impact	24
Designations and Recognition	26

## We activate the potential of Our People

150+

locations  
across North  
America in  
2020

6,410

employees  
as of  
December  
31, 2020

\$1.9M

employee  
development  
investment in  
2020

55%

US employees  
with tenure  
exceeding 5  
years

### Our Values

**We are committed:** innovative, focused, results-oriented

**We act with integrity:** principled, honest, fair

**We make things happen:** agile, driven, passionate

**We win together:** collaborative, dedicated, united

# Employee Health and Safety

**Arcosa is committed to safety across our operations. From frontline workers to plant visitors to office staff, we take pride in our safety training and procedures, settling for nothing less than safety excellence.**

In 2019, we kicked off an enhanced safety initiative: ARC 100. Throughout 2020, the scope of ARC 100 was broadened and foundational activities were implemented to strengthen our engaged safety culture, including the establishment of steering and continuous improvement teams; employee surveys and focus groups; and strategic planning for 2021. Safety-related metrics improved in line with our persistent safety focus, including a year over year improvement in TRIR. These anchoring steps positively position us in our continued pursuit of a sustainable safety culture across the Company.

*The ARC 100 purpose is to spark positive, measurable change in our safety culture by empowering employees to take active ownership in making safety the cornerstone of our lives.*

ARC 100 highlights include:

- Employees from all levels of the organization collaborate to define, implement, and hold each other accountable for safe actions every day.
- Our safety culture is inspired by the voice of frontline employees, driven by multi-level collaboration teams, and actively supported by visible commitment from senior leaders.
- Frontline employees build solutions that leverage preventative action and positive recognition to drive a culture of safety excellence.
- We are committed to an evolving system in which all employees contribute to continuous safety improvements.

<sup>1</sup> Due to the nature and complexity of case management for work-related injuries and illnesses, non-material inputs could minimally affect year-end numbers.

**Total Recordable Incident Rate (TRIR)<sup>1</sup>**

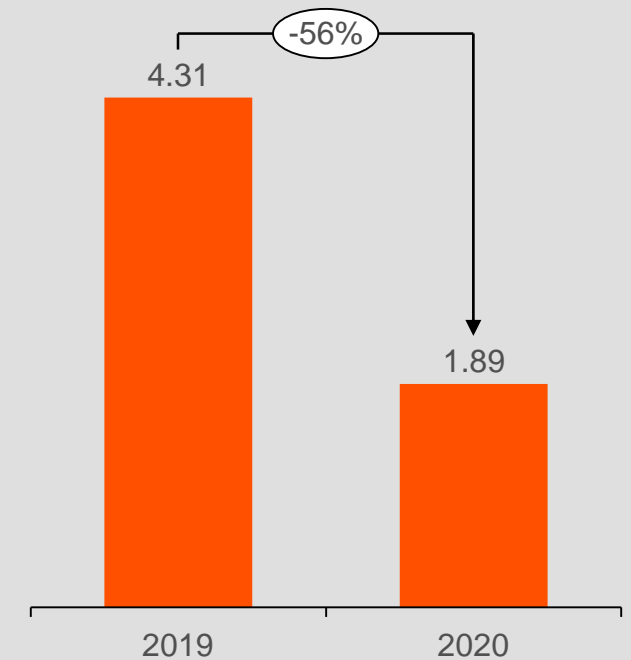

# Inclusion and Diversity

Of the 4 new independent Board members appointed at the time of Arcosa's separation from Trinity Industries, 1 was female and 1 was ethnically diverse.

Females represent 33% of our Senior Management team, including:

- Chief Accounting Officer
- Senior Vice President, Finance & Treasurer
- Vice President, Human Resources

Females represent 20% of our managerial team

- VPs and Directors in Finance, Accounting, Human Resources, Information Technology, and ESG

We are committed to improving the diversity of our workforce and our managerial team through the following initiatives:

Deliver training to bring awareness and educate against unconscious bias.

Drive a diverse slate of internal and external candidates for hiring.

Invest in our employees through development actions that promote women and people of color.

Improve the diversity amongst our professional and management level positions.

Time Horizon 

*Through these initiatives, we believe our Inclusion and Diversity program can grow from compliance to a long-term competitive advantage.*

<sup>1</sup> Mexico operations not included in US workforce metrics in order to highlight US-only diversity

## Race and Ethnic Diversity

US Workforce<sup>1</sup>  
As of December 31, 2020

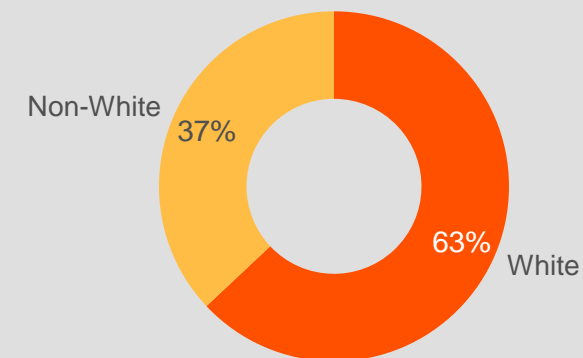

## Gender Diversity

Total Company  
As of December 31, 2020

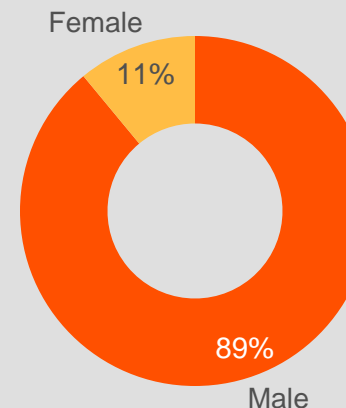

# Talent Management

## Career growth for our employees

Develop dynamic paths to engage, retain and prepare employees for future roles.

## Talent to best serve our customers

Identify job experiences for employees in a variety of roles and responsibilities.

## Reduce future risk for our stakeholders

Identify successors to fill key positions and retain top talent within Arcosa.

**We position Arcosa for growth by developing a broad, deep bench of talent**

## Arcosa fosters development in meaningful ways

### FORMAL PROGRAMS

Harvard “Leading with Finance” online certificate program

McKinsey Black Leadership Academy

Business Acumen training

Positive Management Leadership experience seminar

Young Professionals and Leadership programs

Cherry University

Carnegie Public Speaking

### FINANCIAL SUPPORT

Career path and job-related tuition reimbursement at educational institutions

Professional society memberships in line with employee development

Professional conference and symposia registrations to expand skill sets and career insights

Other educational courses that enhance learning across our businesses and industries

*I'm grateful that Arcosa supports my continued education. Achieving my Masters in Business Administration has been both a personal and professional goal of mine for a long time. The financial support given by Arcosa demonstrates the company's commitment to my growth, and the mentorship shows how invested Arcosa's leaders are in my future.*

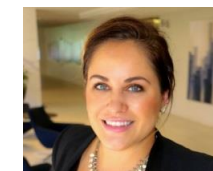

D.W. – Dallas, TX

# Community Impact

Arcosans are building a better world, making our communities better places to live and work. We do this with our dollars, time, and most importantly - with heart



## Supporting the American Heart Association - Protecting the Hearts We Love Campaign

Arcosa put a new spin on the American Heart Association’s (“AHA”) annual Heart Walk in 2020. Due to COVID-19 precautions, and with a desire to engage and encourage employees across the Company to increase their activity, Arcosa’s community impact team innovated the way we walk.



Instead of physically walking together in Dallas at a planned event, Arcosa created a digital platform where employees across the organization could log their steps for an intercompany competition over the course of 30 days. Pedometers were provided as needed and employees were encouraged to protect the hearts they love by walking, running, or biking while tracking their steps.

The Arcosa version of the AHA’s Heart Walk inspired 1,471 Arcosans in the U.S., Mexico, and Canada to walk a combined total of 231,628,724 steps (115,814 miles). Arcosa and its employees also donated directly to the AHA in honor of the Protecting the Hearts We Love campaign, supporting the AHA mission to be a relentless force for a world of longer, healthier lives.



## 2020 United Way Campaign

Each Fall, Arcosa partners with United Way to support their mission of improving lives by mobilizing the caring power of communities around the world to advance the common good. In a year like 2020, we believed it was essential to continue to support the communities where we live and work.

Arcosa’s employees participated in a pledge drive, e-Bingo, e-recipe book creation, and a coloring contest to raise funds and awareness for the many dimensions of United Way.

Continuing the focus on education, income, and health can ensure resilient, unified communities in the face of adversity.





# Community Impact

## Dueling with Purpose



**2020 will be remembered as a year of unprecedented hardships, but also of unprecedented community.** In late summer, Arcosa's Construction Products segment held a friendly contest between the Specialty Materials Division's South Oklahoma food drive and the Aggregates Division's North Texas food drive. Combined, the "Let's Make a Ton" team collected and delivered almost 3,000 pounds (1.5 tons!) of food to their local food banks. Supporting our communities through this "food fight" is another innovative way Arcosans make an impact.

## Facing the Storm Together



**In August 2020, Hurricane Laura made landfall in Southwest Louisiana, causing damage to many communities, including Arcosa's Aggregates plant in Indian Village.** Long power outages and damage to homes and plant buildings created a stressful environment for those in the affected area. 100 miles to the East, one of Arcosa's Lightweight plants, part of a sister division, heard the call to action. The team traveled to the affected plant to provide meals and drinks to Arcosans and their families, as well as to the crews working to restore electricity. Small acts add up as Arcosans show resilience and weather storms together.

## Back to School



**Annually, Arcosa's employees participate in supply drives for their local school districts as students prepare for back to school.** In 2020, Arcosa's barge facility in Missouri delivered 300 supply-filled backpacks to its local schools. Our Wisconsin-based utility structures plant collected supplies and packed 340 backpacks to donate to schools in 3 different local counties. With COVID-19-driven safety precautions looming for the fall semester, Arcosa's Pennsylvania-based forging plant collected and delivered much-needed safety and cleaning supplies to its local middle school. Arcosa believes we win together, and our plants and employees embody this belief every day.

## Biodiversity Preservation



**Over the past century, Louisiana has experienced an exponential increase in annual manatee sightings, with most sightings in the Lake Pontchartrain Basin where Arcosa's Louisiana Barge facility operates.** Since 1991, the population has boomed from 1,200 to over 8,000 manatees. Conservation status moved from endangered to threatened in 2017. In October 2020, our plant partnered with the Louisiana Department of Wildlife and Fisheries to raise awareness and further preserve local wildlife. We posted signage and provided training consistent with local boat launches and marinas to increase employee, customer, and push boat crew awareness of potential protected marine mammal presence in our area; to improve safety of manatees in local waters; and to reduce risk of interaction.

## Designations and Recognition



**VPP OSHA STAR Standouts:** Arcosa's Pennsylvania-based McConway & Torley steel foundry and Standard Forged Products manufacturing facility have maintained VPP OSHA STAR designations for the past 11 years. VPP is OSHA's Voluntary Protection Program which recognizes superior safety and health performance by a facility and its workers. OSHA Star is the highest level of recognition under VPP and designates our facilities as outstanding protectors of employee safety and health.



**ISO 45001 Certification:** As ESG efforts continued to be a high priority across Arcosa in 2020, the Arcosa Wind Towers' manufacturing facilities elevated their safety program by earning their ISO 45001 certification. ISO 45001 aims to aid companies in providing a safe and healthy workplace for employees and visitors by establishing an effective occupational health and safety management system. Certification against this standard exemplifies our commitment to furthering the culture of safety at Arcosa.



**Latinos on Boards Recognition:** Arcosa's Joe Alvarado, an independent director on the Company's Board, as well as President and CEO Antonio Carrillo were named to the Latino Leaders Magazine's Latinos on Boards 2020 list. Mr. Alvarado is also featured in the magazine's August/September 2020 edition, highlighting his extensive experience in the steel industry, as an executive, and now as a Board member.



**Cemefi ESR Distinction:** Arcosa Mexico received the Empresa Socialmente Responsable (ESR) badge from the Mexican Center for Philanthropy (Cemefi) and AliaRSE. The badge acknowledges a company's exceptional commitment to employee wellbeing, business ethics, environmental management, and community impact after a thorough review of company practices. Our Mexico team's strong commitment to these areas of ESG and the recognition of their efforts is another positive step on Arcosa's sustainability journey.

## Our Environment

TCFD Disclosure	28
Energy Management and GHG Emissions	37
Water Management	38
Land Management	39
Recycled Materials	40

## We Support the Sustainability of Our Environment

**Arcosa is committed to integrating ESG into our daily practices and long-term strategies. In line with that commitment and in support of furthering our environmental transparency, we have aligned our climate-related disclosures with the recommendations of the Financial Stability Board’s Task Force on Climate-related Financial Disclosures (“TCFD”).**

Climate impacts, while often viewed through a lens of risk, also present Arcosa with opportunities for growth. We are optimistic that the Company’s structure and our business fundamentals position us to thrive in an uncertain future.

The following pages provide an update on each of the four core recommendations of the TCFD: Governance; Strategy; Risk Management; Metrics and Targets.



# TCFD Overview



## Governance

Disclose the organization's governance around climate-related risks and opportunities

### Recommended Disclosures

- › [Pg 30](#) - Describe the board's oversight of climate-related risks and opportunities.
- › [Pg 31](#) - Describe management's role in assessing and managing climate-related risks and opportunities.



## Strategy

Disclose the actual and potential impacts of climate-related risks and opportunities on the organization's businesses, strategy, and financial planning where such information is material

### Recommended Disclosures

- › [Pg 32-33](#) - Describe the climate-related risks and opportunities the organization has identified over the short, medium, and long term.
- › [Pg 32-33](#) - Describe the impact of climate-related risks and opportunities on the organization's businesses, strategy, and financial planning.
- › [Pg 34](#) - Describe the resilience of the organization's strategy, taking into consideration different climate-related scenarios, including a 2°C or lower scenario.



## Risk Management

Disclose how the organization identifies, assesses, and manages climate-related risks

### Recommended Disclosures

- › [Pg 35](#) - Describe the organization's processes for identifying and assessing climate-related risks.
- › [Pg 35](#) - Describe the organization's processes for managing climate-related risks.
- › [Pg 35](#) - Describe how processes for identifying, assessing and managing climate-related risks are integrated into the organization's overall risk management.



## Metrics and Targets

Disclose the metrics and targets used to assess and manage relevant climate-related risks and opportunities where such information is material

### Recommended Disclosures

- › [Pg 36-40, 49](#) - Disclose the metrics used by the organization to assess climate-related risks and opportunities in line with its strategy and risk management process.
- › [Pg 49](#) - Disclose Scope 1, Scope 2, and, if appropriate, Scope 3 greenhouse gas (GHG) emissions, and the related risks.
- › [Pg 36](#) - Describe the targets used by the organization to manage climate-related risks and opportunities and performance against targets.

# TCFD Governance: Board of Directors



Arcosa’s **Board of Directors** (“Board”) has ultimate responsibility for risk oversight, including but not limited to climate-related risk. Management reviews and discusses risks and opportunities with the Board as part of the business conducted at each of the regular meetings of the Board. While the Board has primary responsibility for overseeing the Company’s risk management, each committee of the Board also considers risk within its area of responsibility. Each committee regularly reports back to the Board on its risk oversight activities. Specifically, the Governance and Sustainability and Audit Committees oversee specific types of climate-related risks and opportunities.

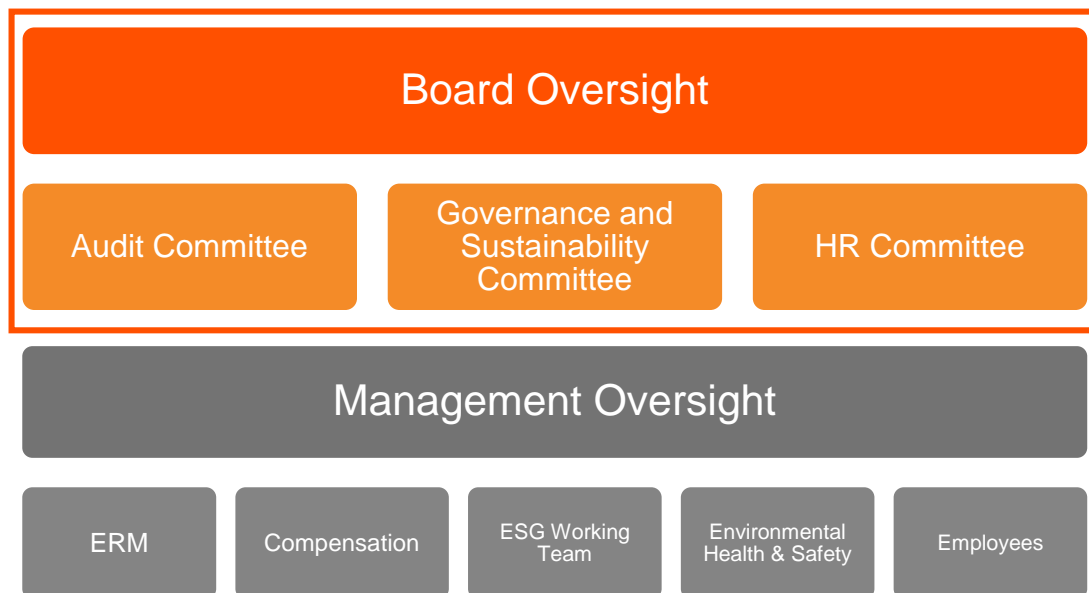

The **Governance and Sustainability Committee** oversees on behalf of the Board risks related to our governance structure and director compensation programs; and provides oversight and reviews and assesses the Company’s significant risks, opportunities, activities and practices regarding ESG-related matters.

The **Audit Committee** oversees on behalf of the Board material financial, legal, and regulatory risk exposures and steps taken by management to address the same. The Audit Committee’s responsibilities include but are not limited to oversight of: the integrity of the Company’s financial statements and related disclosures; the Company’s compliance with legal and regulatory requirements; the Company’s independent auditing firm; the performance of the Company’s internal audit function; the Company’s internal accounting and disclosure control systems; the Company’s procedures for monitoring compliance with its Code of Business Conduct and Ethics; the review and assessment of information technology and cyber security risk exposures and the steps taken to monitor and control those exposures; and risks identified during the internal and external auditors’ risk assessment procedures.

**Human Resources Committee** oversees on behalf of the Board risks related to a broad range of social issues, including but not limited to oversight of the Company’s inclusion and diversity program; management of succession planning and awards under the Company’s incentive compensation and equity based plans; evaluation of the leadership and performance of the Company’s CEO, with compensation recommendations to the Company’s independent directors; and compensation review and approval for the other named executive officers.



# TCFD Governance: Management

Arcosa’s senior management team has implemented multiple strategies for assessing and managing climate-related risks and opportunities.

**Enterprise Risk Management (“ERM”):** Arcosa’s Internal Audit team facilitates a proactive, structured process for identifying and mitigating market, operational, climate-related, financial, infrastructural, and reputational risk. The Audit Committee is responsible for direct oversight of the ERM process, with the entire Board providing overall review and guidance.

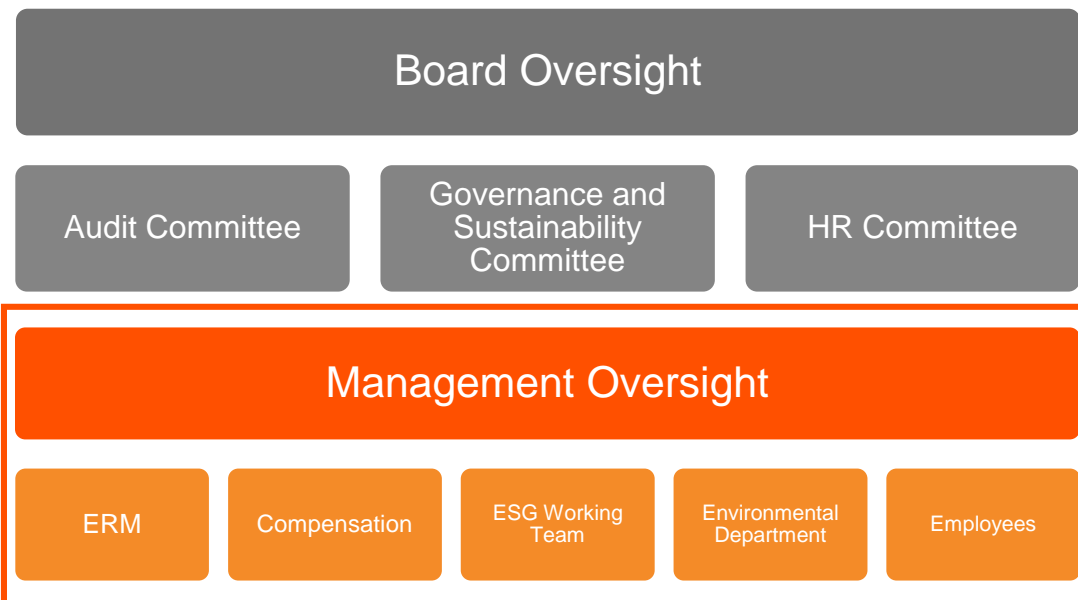

**Compensation:** The compensation of named executive officers and a number of additional employees is linked to ESG specific goals.

**Director of ESG, Business Unit ESG Leads:** The development and execution of Arcosa’s ESG program company-wide includes initiatives and activities aimed at sustainability improvements in many categories, including but not limited to reductions in GHG emissions related to climate change. The ESG team is responsible for ensuring visibility to the executive team, and subsequently to the Governance and Sustainability Committee. Additionally, the ESG team proactively communicates and advocates corporate sustainability initiatives to the stakeholder base, including those related to energy management.

**VP of EH&S and Business Unit EH&S Directors:** Arcosa’s Environmental Health and Safety team includes corporate leadership and environmental subject matter experts that provide direct guidance throughout the business. This team provides oversight of environmental matters, including but not limited to regulatory compliance and reporting and environmental initiative action plans.

**Employees:** Arcosa’s employees are crucial to the success of the ESG program. Employees are encouraged to identify continuous improvement opportunities through process knowledge and innovative thinking. Arcosa’s employees have championed many initiatives directly aimed at reducing energy consumption and GHG emissions.



# TCFD Strategy: Risks and Opportunities

Arcosa's Board and executive management team have established a layered structure for identifying company-wide risks and opportunities. Using a formal Enterprise Risk Management process along with business leader expertise, we identify risks across the organization. Frequent strategic planning aids in identification of opportunities to make the company more resilient

	Time Horizon			Climate-Related Opportunities
	Short <5 years	Med 5-10 years	Long 10+ years	
<b>Climate-Related Risks</b>				
<b>Policy and Regulatory</b>				
Carbon tax - emissions limits	●	●		A transition to emission limits in the US may present opportunities for partnerships with renewable energy providers and others for carbon offsets. As the market looks for low-carbon alternatives, certain Arcosa product lines may benefit from the transition to more efficient modes of transportation. Added demand to strengthen infrastructure across the US to support clean energy may also present growth opportunities for our wind tower and transmission structures businesses.
Stricter regulation of sustainability reporting	●			Arcosa has the opportunity to leverage current governance strengths to align with changes to many types of emerging regulatory reporting.
Mandates on and regulation of existing product lines	●			Arcosa demonstrated our ability to grow in low-emission product lines through our entrance into recycled aggregates, a new product category for Arcosa, through two acquisitions in 2020.
Changing regulation of North American pipeline infrastructure	●			Short-term reluctance to support build out of pipeline infrastructure could result in opportunities for Arcosa's transportation-related product lines. Additionally, the potential for higher steel availability across the market may improve raw material pricing for our manufacturing businesses.
<b>Technology</b>				
Cost of transition to lower emission technology	●	●		Arcosa evaluates the cost/benefit of lower emission technology as part of our operations and asset purchase reviews. Opportunity exists as possible regulatory incentives alleviate the cost differential between purchase options.
Electricity grid reliability due to higher usage	●	●		As the limits of the electricity grid are tested, opportunities arise to internally improve production efficiency to counter potential grid instability. Arcosa's resilience is evident in our geographic diversity, with plants in varying regions across North America ensuring mitigation against any material standstill. Additionally, Arcosa's utility structures business benefits from infrastructure builds to support higher volumes of US energy consumption, and Arcosa Tank provides propane storage in regions with demand for reliable backup energy supply.
Price increases due to variability of renewable sources	●	●		In line with electricity availability, opportunity exists to mitigate price increases through cost cutting measures in other operational processes, as well as the implementation of new technologies to reduce energy consumption overall.
<b>Market</b>				
Increased cost of raw materials	●	●	●	We see opportunities to leverage our purchasing power to mitigate some of the potential impact of material cost increases. Innovative and strategic focus to eliminate possible waste in our production processes also presents opportunities for cost mitigation.
Unreliable supply chain	●	●		Opportunity exists to diversify supplier base to rely on sustainability-focused suppliers which are often more resilient. As climate change increasingly impacts companies in our markets, Arcosa provides reliability where other less diversified companies may be challenged.
Change in customer behaviors	●	●		As customers shift to find energy efficiency and lower emission options, opportunities arise for our low-emission product lines such as recycled aggregates and wind towers.
<b>Reputation</b>				
Stigmatization of less "green" down stream products	●	●		Diversification of products across Arcosa allows us to maintain a balanced emissions portfolio. Opportunity exists for further acquisitions into low-emission products and platforms, as well as investment in technology to reduce energy and water consumption in current production processes.
Stigmatization of less "green" production processes	●	●		
Stigmatization of less "green" upstream products	●	●		Additionally, participation in energy reduction programs and carbon credit initiatives should allow us to reduce our carbon footprint overall.



# TCFD Strategy: Risks and Opportunities



		Time Horizon			Climate-Related Opportunities
		Short <5 years	Med 5-10 years	Long 10+ years	
Physical Risks	<b>Climate-Related Risks</b>				
	<b>Acute</b>				
	Increased severity of natural disaster impacts and insurance coverage	●			At Arcosa, we have the opportunity to leverage EHS-driven business continuity plans to ensure resilience across our operating facilities. Geographic diversity allows us to adapt to high and low temperatures at intervals, rather than at all locations at once. We also see the opportunity to mitigate operational risks by improving production efficiency and reliability as part of routine strategic planning. Arcosa is favorably positioned to support reconstruction in the market during times of severe weather patterns through our engineered structures product lines and construction product lines including demolition, recycled and natural aggregates businesses.
	Extreme temperatures limit operating hours or days	●			
	Extreme temperatures affect employee health and safety	●	●	●	
	Higher rainfall and intense wind affect production and delivery schedules	●	●	●	
	<b>Chronic</b>				
	Changes in precipitation patterns and extreme variability in overall weather	●	●		Long-term weather and climate impacts bring opportunities to evaluate acquisition and organic growth in lower risk regions; to affect change by investing in new technologies; and to rely on the resilience we are building through sustainable operational practices.
	Rising average temperatures	●	●	●	
	Rising ocean and river levels and increased flooding may adversely impact operations	●	●	●	
Inconsistent access to reliable electricity supply	●	●	●		

The table above provides a look at Arcosa's short, medium, and long-term time horizons and associated climate-related risks and opportunities.

**In a rapidly changing world, we believe our resilience is built through adaptability to meet the evolving needs of our stakeholders.** The climate-related risks we identified could be detrimental to our businesses if not addressed; however, these risks are at the forefront of our business and financial strategy and are addressed through thoughtful collaboration by our business leaders and Board of Directors.

We are optimistic for the future as we explore opportunities to accelerate organic and acquisition growth in low emission product lines, to position existing environmentally friendly businesses for future success, and to build a resilient and geographically diverse company.

# TCFD Strategy: Scenario Analysis



To understand the impact climate change could have on Arcosa, we performed a high-level review of the impact of a 2°C global warming scenario. This scenario was developed based on global temperature increases expected by 2100.

Over the next 80 years, gradual environmental changes may occur that impact our businesses. With this concept in mind, we reviewed a shorter 10-year horizon, to see impacts possible by 2030. We excluded not-yet-executed outside opportunities in this scenario.

Under this scenario, Arcosa could have financial risk without action taken; however, it does not materially change the fundamentals of our business strategy. Our strength is visible in the diversification of our portfolio and the established governance of our operating strategy.

## 2°C Climate Impact Scenario

### Assumptions:

- › Rapid and aggressive action to address climate change including regulations of GHG emissions, restrictions on deforestation, and water conservation initiatives.
- › Physical impact of climate change minimized.

### Business Impact:

- › Carbon pricing enacted as an emissions management alternative, subsequently raising operating costs and costs along the supply chain.
- › Arcosa benefits from market transition to lower emission product offerings in current portfolio and market transition to more efficient modes of transportation.

# TCFD Risk Management



Identification and assessment of risk is a routine part of any business. Arcosa operates in multiple, complex industries where opportunities and risks cannot always be separated. We believe it is important to regularly review both the risks and opportunities of our businesses and to strategize for future success.

**Arcosa's Risk Management Team** provides direct input at both the Arcosa corporate level and the individual business level to manage climate-related risks through evaluation, selection and review of appropriate insurance coverage; organic risk mitigation strategy collaboration, including capital spend planning; and risk prevention strategies.

**Arcosa's Legal Team** provides mitigation and prevention strategies and overall guidance across the business in response to ESG risks, opportunities, and strategic direction.

**Arcosa's Senior Management Team** monitors for micro and macro trends in the industries where we operate to actively identify and prepare for climate-related impacts. From monthly business reviews to annual strategic planning, business unit leadership and senior management build business processes to address changes to supply chain resilience, customer preferences, industry norms, workforce reliability, weather patterns, and new technology.

**Arcosa's Enterprise Risk Management Process** is a proactive, structured process for identifying and mitigating market, operational, climate-related, financial, infrastructural, and reputational risk. We identify and assess climate-related risks through the ERM process, with input from both internal and external sources. Arcosa's ERM framework is dynamic in its application across all business units and risk-related topics, supporting management in the effective management of risk. Climate-related risk is a large part of the ERM process, as we are focused not only on Arcosa's impact on the environment, but also the environment's impact on Arcosa. The formal ERM process is designed to enable consistent and frequent communication between accountable management, executive leadership, and the Board.

# TCFD Metrics and Targets



**2020 is Arcosa’s first full year of ESG disclosure. We have adopted Sustainability Accounting Standard Board’s (“SASB”) reporting standards.**

We continue to research, develop, measure, and set baseline data levels, with broadening disclosure expected as our sustainability program matures. Once baseline data is comprehensive, we expect to develop specific targets to compare against performance.

Arcosa’s plant operations continue to take an active role in pursuing initiatives that promote environmental responsibility.

## Example Projects

Arcosa’s Meyer Utility Structures researched and implemented lower psi on all plant air compressors. This no-cost change will result in lower scope 2 emissions over time.



Arcosa Marine is sponsoring a tree planting project that will improve swamplands along the coast of Louisiana’s Pontchartrain Basin.



Arcosa’s Construction Products businesses transitioned to higher efficiency engines to reduce fuel consumption (scope 1 emissions), improve production volumes, and decrease priority pollutants.



# Energy Management and GHG Emissions

At Arcosa, we believe we can play a role in addressing the global climate challenge through strategic management of energy consumption and corresponding greenhouse gas (“GHG”) emissions. We are dedicated to developing initiatives that reduce GHG emissions as reductions lead directly to climate improvement, improved financial returns, and organizational resilience.

Throughout 2020, our facilities made improvements in energy consumption, including investment in motion-sensor and LED lighting improvements, energy efficient fixed asset replacement purchases, focused production scheduling to minimize consumption in down time, and energy surveys to identify opportunities for future energy reduction projects.

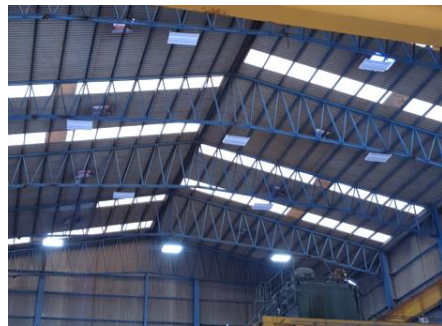

*During 2020 facility upgrades at Arcosa’s Huehuetoca, Mexico manufacturing facility, the plant installed translucent, polycarbonate sheet panels to increase use of natural light.*

*These changes improved visibility within the facility, with an overall reduction in energy consumption.*

## GHG Emissions<sup>1</sup>

(Metric Tonnes of CO2 equivalent in Thousands)

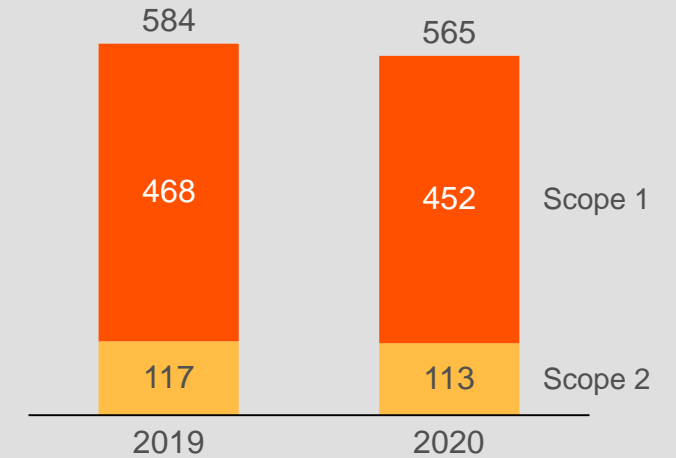

## GHG Emissions Intensity<sup>1</sup>

(Metric Tonnes of CO2 equivalent / Revenue in Millions)

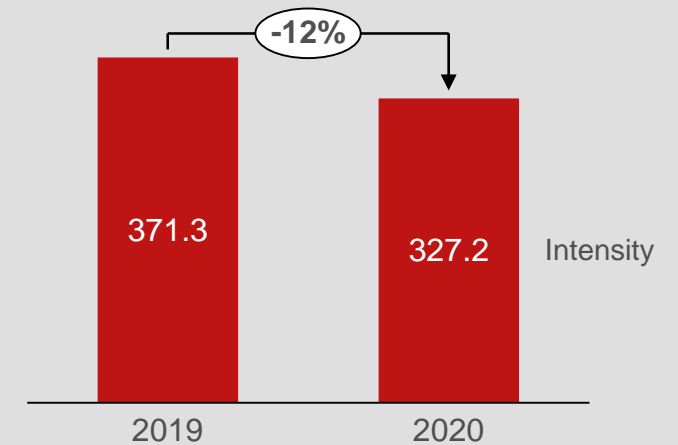

<sup>1</sup> Revenue and emissions of acquisitions completed within the previous 12 months, while these acquisitions are integrated into our emissions reporting systems.

# Water Management

**Water is an essential part of Arcosa’s environmental footprint.** We use water in both manufacturing and manufacturing support processes, aiding in the safety and quality of our products. Our conservation efforts are focused on efficient water consumption, broadening use of water recycling processes where they do not yet exist, and improved data capture and disclosure in plants with existing recycling processes.



*Arcosa continues to advance ESG focus at all our facilities, and acquisitions are no exception.*

*In 2020 following Arcosa’s acquisition of Cherry, two recycled aggregates locations in Houston, TX installed new detention ponds to capture water runoff. This water can replace municipal and groundwater consumption in the plants’ production processes, furthering our recycling efforts.*

## Water<sup>1</sup> (Kilogallons)

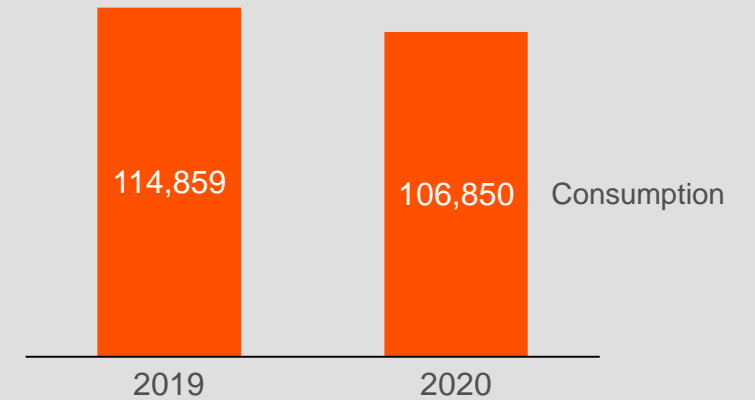

## Water Intensity<sup>1</sup>

(Kilogallons / Revenue in Millions)

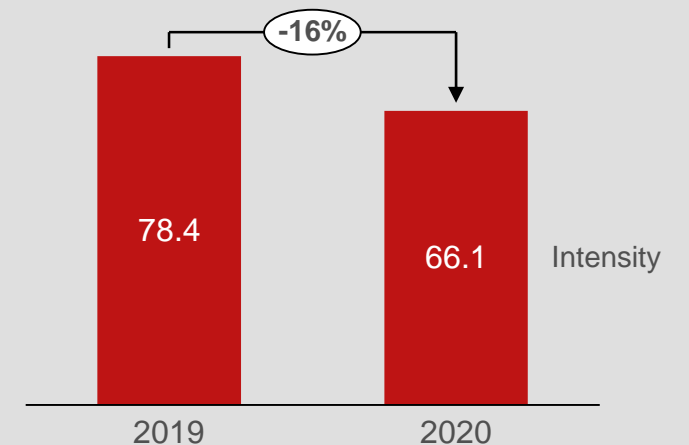

<sup>1</sup> Consumption represents municipal water consumed in the period. Revenue and consumption amounts from acquisitions completed within the previous 12 months, while these acquisitions are integrated into our emissions reporting systems.

# Land Management

**Arcosa's natural aggregates business is building and developing projects that exemplify sustainability efforts in land management.**

Arcosa's Texas reclamation project brings into focus two areas where we believe Arcosa has made a significant and lasting environmental impact: land reclamation and water conservation.

Land reclamation can be achieved in many ways, but the Curry, Texas project began with discovering a way to optimize the retention of storm water and mine impoundment water, which could then be used in the natural aggregates production process. We were able to temporarily convert a sizeable amount of leased farmland to develop a water reservoir for the recycling of water to be used repeatedly without wastewater discharge. The internally designed reservoir was built and lined with bentonite, a volcanic clay, which maximized the water conservation.

When the project was complete, the land owners requested that we leave the reservoir intact. The remainder of the reclaimed land was then turned back into farmland using the new reservoir as an embedded irrigation system for crops.



Mine Reclamation



Post Reclamation Farmland

## Recycled Materials

Arcosa's commitment to environmental responsibility extends to sourcing of steel used in our many manufacturing facilities. We partner with steel suppliers to manage the environmental impact of material in both production and disposal.

By targeting fifty percent or more total recycled steel material used to build our products, we believe we can meet the needs of our customers and positively impact emissions over time.

We saw a stable, favorable trend of sourced recycled steel from 2019 to 2020, with overall composition remaining unchanged.

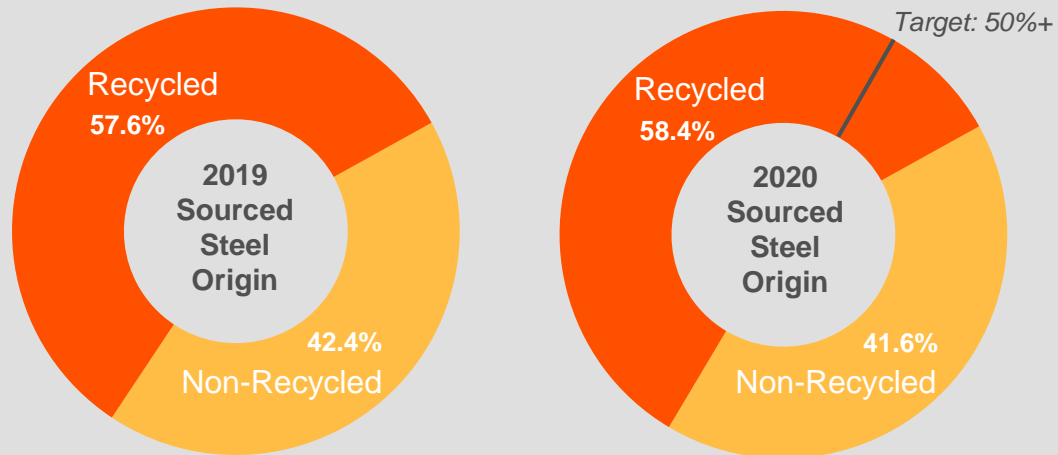

*Arcosa's McConway & Torley steel foundry in Pittsburgh, PA operates as a leader in our material stewardship. Its high quality products are cast using mostly scrap steel in the melt process.*



## Our Products

Recycled Aggregates	43
Arcosa Wind Towers	44
Arcosa Marine	45
Arcosa Shoring Products	46

# Our products are used in important, environmentally friendly industries

Arcosa operates in multiple industries which contribute to environmental protection



Arcosa Wind Towers produces steel towers to support our customers' advancement of America's wind energy infrastructure.



Arcosa Marine builds barges for the fuel-saving and efficient movement of commodities across the country's inland and coastal waterways.



Arcosa's Recycled Aggregates business provides an alternative to using natural resources by recycling concrete, asphalt, steel, and asphalt shingles, which also minimizes landfill use and reduces roadway traffic and vehicle emissions.



Arcosa's Meyer Utility Structures manufactures engineered, tubular, and lattice steel structures for electricity transmission and distribution from wind, solar, and other environmentally friendly resources.



Arcosa's Steel Components businesses manufacture railcar components for the fuel-saving and efficient movement of commodities across the country.

# Recycled Aggregates

In 2020, our construction products footprint grew through two recycled aggregates acquisitions: Cherry Industries and Strata Materials. Arcosa's Recycled Aggregates business plays an integral role in our ESG program. Our business sources the majority of raw materials from Construction and Demolition (C&D) debris, aligning with Arcosa's goal of environmental responsibility through increased use of recycled materials in our production processes.

Annually, Arcosa recycles:

Nearly four million tons of concrete for use in road base material.



Over 200,000 tons of reclaimed asphalt for use in hot mix material.



Over 20,000 tons of steel to fabricate new steel products.



C&D debris recycling:

- According to the EPA, 569 million tons of C&D debris were generated in 2017.
- 73% of C&D debris is recycled.
- Recycled asphalt saves US taxpayers ~\$2.5B annually.
- Recycled C&D debris saves landfill space, conserves natural resources, reduces greenhouse gas emissions, creates jobs, and decreases road congestion.

Sources: [Environmental Protection Agency](#); [C&D Recycling Association \(CDRA\)](#); [National Asphalt Pavement Association](#)

## Arcosa Wind Towers



# 198M

metric tons of CO2 emissions avoided in 2019 through wind energy; equivalent to 43 million cars' worth of emissions.

# 60,000+

Wind turbines operate across the United States, generating enough wind power to serve the equivalent of 34 million American homes.

# \$14B

Industry investments in new wind projects in 2019.

*As a leading wind tower manufacturer with over 13,500 towers produced, **Arcosa** plays an important role in the development of America's wind energy infrastructure. In addition to emissions avoidance, wind energy allows for water conservation compared to thermal power plants.*

Source: [American Clean Power](#)

# Arcosa Marine

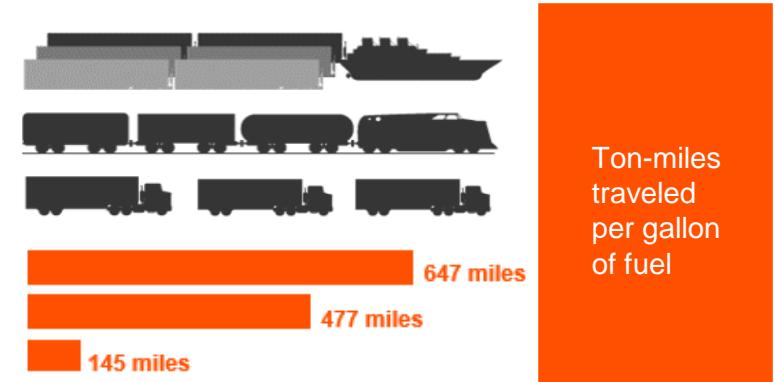
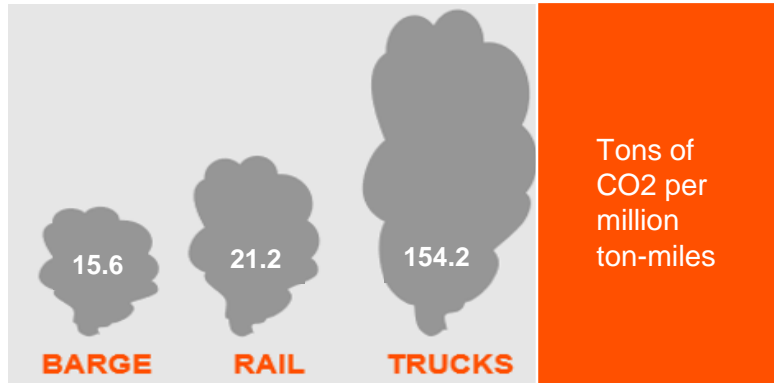

Source: [National Waterways Foundation](#)



*Arcosa Marine builds barges for the fuel-saving and efficient movement of commodities across America’s inland and coastal waterways.*

# Arcosa Shoring Products

Arcosa provides a valuable product to the underground construction market as a leading provider of steel and aluminum trench shields. Our products provide value to the environment as well as to our customers' workforce and operations.

*Increasingly sustainable with minimized land displacement*

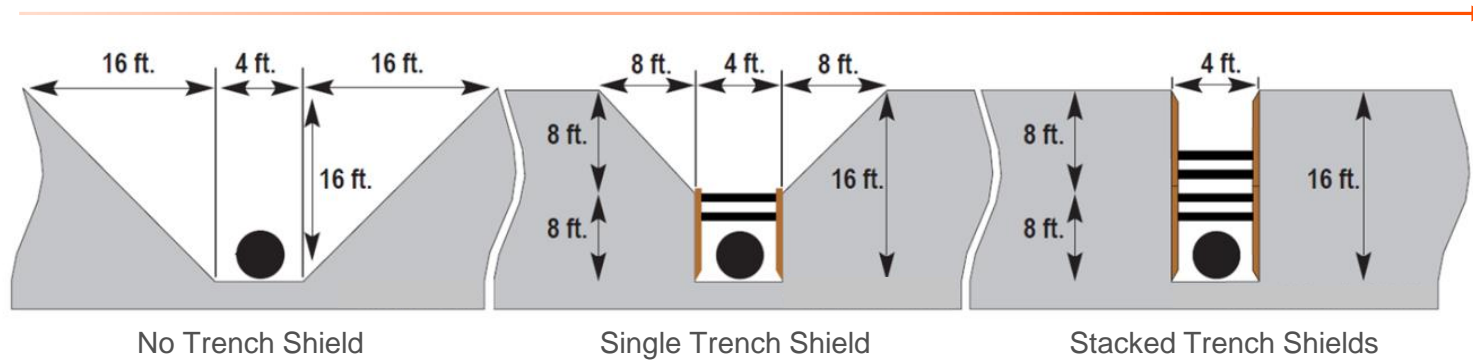

*Trench Shield Benefits include improved employee health and safety, higher productivity, reduced transportation costs and emissions, and minimized land displacement.*



Arcosa trench shield products

# Appendix

# Appendix

At Arcosa, sustainability means strengthening the positive interactions we have with the world around us to drive long-term value and corporate resilience. As a provider of infrastructure-related products and solutions with leading positions in construction, engineered structures, and transportation markets, we believe we can create long term value for our broad range of stakeholders by driving a culture that values ESG responsibility.

The following reference tables contain disclosures relevant to Arcosa's ESG program. In correlation with our TCFD response, we have included a broadened set of select metrics from SASB, including standards for the multiple sectors in which we operate: (1) Extractives & Minerals Processing – Construction Materials Sector; (2) Resource Transformation – Industrial Machinery & Goods Sector; and (3) Renewable Resources & Alternative Energy – Wind Technology & Project Developers Sector.

The tables also reference select United Nations Sustainable Development Goals (UN SDGs).







In 2020, we continued to integrate ESG into our daily practices and long-term strategies through ESG-focused initiatives and innovative continuous improvement projects. As we transition to 2021, we keep ESG at the forefront of our priorities, understanding the actions we take today can have broad and far-reaching impact for future generations. At Arcosa, we are unified in our commitment to build a better world.

**TCFD** | TASK FORCE ON CLIMATE-RELATED  
FINANCIAL DISCLOSURES









# Reference Table - Environmental

Environmental Topic	Metric	Unit of Measure	2019	2020	Disclosure Commentary	SASB Code	UN SDG	Page
Air Quality	Air emissions of the following pollutants: (1) NOx (excluding N2O), (2) SOx, (3) particulate matter (PM10), (4) dioxins/furans, (5) volatile organic compounds (VOCs), (6) polycyclic aromatic hydrocarbons (PAHs), and (7) heavy metals	Metric Tons (t)			In process	EM-CM-120a.1	 	
	Number of Air permits	Number			In process			
	Dollars spent on air quality	Dollars			In process			
Energy Management	(1) Total energy consumed, (2) percentage renewable	(1) Gigajoules (GJ) (2) Percentage	1) 6,942,180 2) In Process	1) 6,976,517 2) In Process		RT-IG-130a.1 EM-CM-130a.1		
GHG Emissions	(1) Gross global Scope 1 emissions, (2) percentage covered under emissions-limiting regulations	(1) Metric tons (t) CO2-e (2) Percentage	1) 467,856 2) In Process	1) 451,977 2) In Process		EM-CM-110a.1		37
	Gross global Scope 2 emissions	Metric tons (t) CO2-e	116,570	113,419				37
	Discussion of long-term and short-term strategy or plan to manage Scope 1 emissions, emissions reduction targets, and an analysis of performance against those targets	Discussion			In process	EM-CM-110a.2		
Land Management	Number of Sites Reclaimed	(1) Number of Sites (2) Discussion			(1) In process (2) Disclosure included in report.			39
Recycled Materials	Description of the management of risks associated with the use of critical materials.	Discussion			For our manufacturing businesses, the management of steel at the source is an important way we can manage waste. We believe we can reduce landfill use by sourcing steel that is made from recycled metals.	RR-WT-440a.1 RT-IG-440a.1		
	Analysis of composition of steel purchased (recycled versus non-recycled material)	Percentage	Recycled Steel 57.6%; Non-Recycled Steel 42.4%	Recycled Steel 58.4%; Non-Recycled Steel 41.6%	Arcosa has partnered with our steel suppliers to focus on material management for our manufacturing operations. We target 50% or greater acquisition of recycled steel for our steel manufacturing processes.			40
Waste/Hazardous Materials Management	Description of initiatives to reduce waste and properly manage hazardous materials.	Discussion			In process			
Water and Wastewater Management	(1) Total fresh water withdrawn, (2) percentage recycled, (3) percentage in regions with High or Extremely High Baseline Water Stress	(1) Thousand cubic meters (m³) (2) Percentage (3) Percentage	1) 434.8 2) In Process 3) In Process	1) 404.5 2) In Process 3) In Process	Disclosure includes purchased water across US operations.	EM-CM-140a.1		38



# Reference Table - Social and Governance

Social Topic	Metric	Unit of Measure	2019	2020	Disclosure Commentary	SASB Code	UN SDG	Page
Employee Health & Safety	(1) Total recordable incident rate (TRIR), (2) fatality rate, and (3) near miss frequency rate (NMFR)	Rate	1) 4.31 2) In Process 3) In Process	1) 1.89 2) In Process 3) In Process		RR-WT-320a.1 RT-IG-320a.1 EM-CM-320a.1		
Talent Management	Talent Recruitment Activities	Discussion			In process			
	Talent Development Activities	Discussion			Disclosure included in report.			23
Community Engagement, Social Investment	Amounts contributed to charitable and non-profit organizations for the betterment of our communities.	Dollars			In process			
	Employee volunteer hours	Number of Hours	12,036	2,939	Due to the COVID-19 pandemic and the elimination of in-person events, volunteer hours declined in 2020.			
Diversity	Employee (1) race/ethnic and (2) gender diversity	Percentage	(1) White 67%, Non-White 33% (2) Male 88%, Female 12%	(1) White 63%, Non-White 37% (2) Male 89%, Female 11%	2019 data compiled from our 2020 mid-year ESG update, using July 2020 data. 2020 data as of 12/31/2020.		 	22

Governance Topic	Metric	Unit of Measure	2019	2020	Disclosure Commentary	SASB Code	UN SDG	Page
Corporate Governance	Independent Board Members	Percentage	89%	89%				15
	Board Ethnic Diversity	Percentage	22%	22%				15
	Board Gender Diversity	Percentage	11%	11%				15
	Board Oversight of ESG	Discussion			The Arcosa Board of Director's Governance and Sustainability committee is responsible for oversight of the Company's initiatives in relation to ESG matters.			14
	Business Ethics and Compliance Training	(1) Number and (2) Percentage of Employees Trained	(1) Number and (2) Percentage of Employees Trained	1) 6,275 2) 100%	1) 6,410 2) In Process	Operating in the regular course of business, employees complete annual training and certification for Arcosa's Code of Business Conduct and Ethics. In 2020, due to COVID-19 safety precaution limitations on class size for in-person training, percentage is still in process and may decline slightly overall.		

# Non-GAAP Measures

## Reconciliation of Adjusted EBITDA

	Year Ended December 31 , 2020
(\$'s in millions) (unaudited)	
<b>Net income</b>	<b>\$106.6</b>
Add:	
Interest expense, net	10.2
Provision for income taxes	31.6
Depreciation, depletion, and amortization expense <sup>1</sup>	114.5
<b>EBITDA</b>	<b>262.9</b>
Add:	
Impact of acquisition-related expenses <sup>2</sup>	10.3
Impairment charge	7.1
Other, net (income) expense <sup>3</sup>	3.4
<b>Adjusted EBITDA</b>	<b>\$283.7</b>

“EBITDA” is defined as net income plus interest, taxes, depreciation, depletion, and amortization. We adjust EBITDA for certain items that are not reflective of the normal earnings of our business (“Adjusted EBITDA”). GAAP does not define EBITDA or Adjusted EBITDA and they should not be considered as alternatives to earnings measures defined by GAAP, including net income. We use Adjusted EBITDA to assess the operating performance of our consolidated business, as a metric for incentive-based compensation, as a measure within our lending arrangements, and as a basis for strategic planning and forecasting as we believe that it closely correlates to long-term shareholder value. As a widely used metric by analysts, investors, and competitors in our industry, we believe Adjusted EBITDA also assists investors in comparing a company's performance on a consistent basis without regard to depreciation, depletion, amortization, and other items which can vary significantly depending on many factors.

<sup>1</sup> Includes the impact of the fair value markup of acquired long-lived assets.

<sup>2</sup> Expenses associated with acquisitions, including the cost impact of the fair value markup of acquired inventory and other transaction costs.

<sup>3</sup> Included in Other, net (income) expense was the impact of foreign currency exchange transactions.

**ARCOSA**

500 N. Akard Street, Suite 400

Dallas, Texas 75201

(972) 942-6500

[www.arcosa.com/sustainability](http://www.arcosa.com/sustainability)